

# autop Eurolift 2.30 Pv

140-200, 160-220



## OPERATIVE RANGE

Check-in, repair and maintenance



## PARTICULAR FEATURES

**Hydraulic twin-ram inground lift for reception and repair.**

## APPLICATION

The Eurolift 2.30 Pv „repair“ is a simple and solid hydraulic car lift, appropriate to lift up a great range of vehicles.

The drive-on is comfortable and the length-adjustment is very easy, even if the car is already on the lift.

Handy accessories as rubber blocs complete this standard lift.



**autop**<sup>®</sup>  
Upwards in security!



# autop Eurolift 2.30 Pv 140-200, 160-220



## TECHNICAL DATA

Lifting capacity:	3000 kg
Piston distance:	1335 mm
Lifting height:	1920-2000 mm
Stroke length:	1850 mm
Lifting/lowering time:	30 sec.
Cylinder diameter:	2 x 123 mm
Foundation depth:	2615 mm
Voltage:	230/400 V/50 Hz
	16 A
Pump unit:	2.2 kW

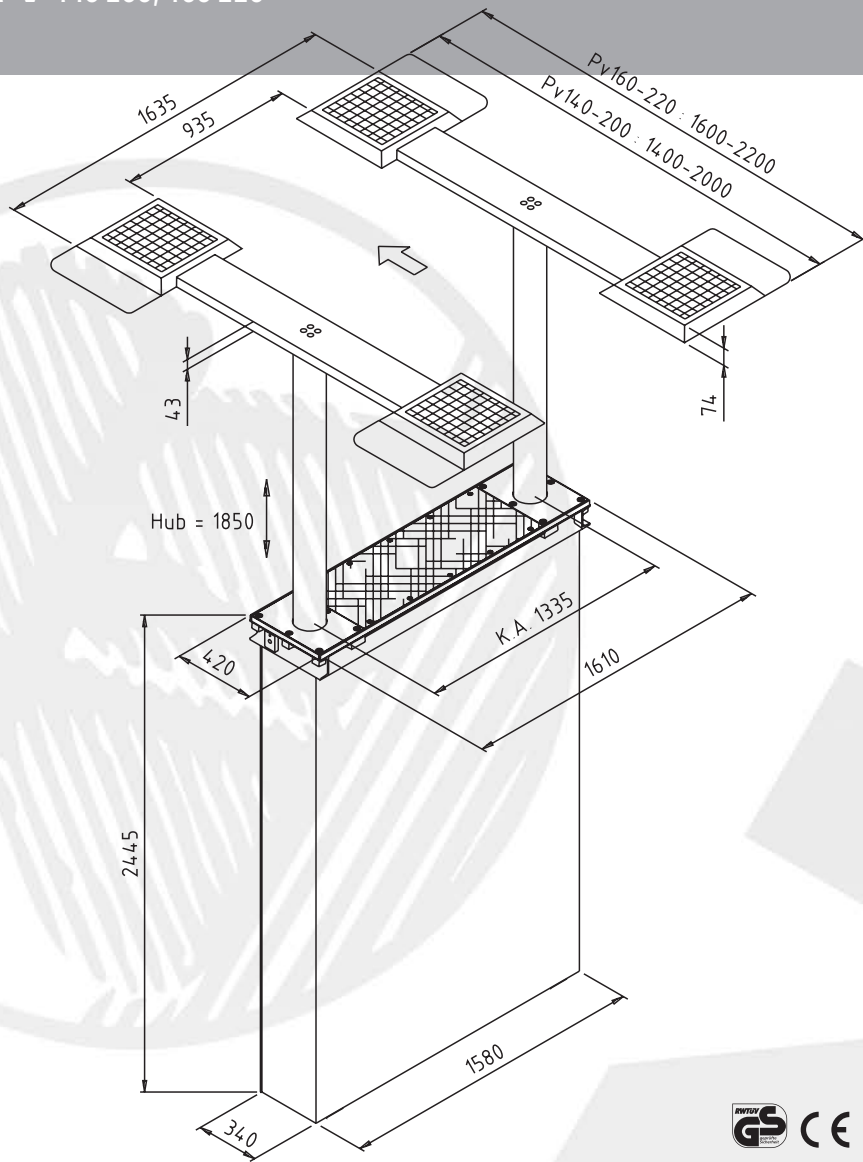

No liability accepted for specifications that are subject to alteration - validity of/for The data and pictures in this product information are not binding and are only giving an approximate description. Moreover we reserve the right of differences between the goods delivered and the data and pictures given here (i.e. technical data, equipment, material and optical appearance) so far as the differences are reasonable for the customer and a possible reduction in value or utility value of the goods delivered is not considerable.



## COMPONENTS

- Two inversed hydraulic cylinders made of micro-alloyed high grade steel with hard-chrome plated surface; cylinder running on teflon sliding rings.
- Bearing guide elements made of high quality special alloy, wear resisting.
- Flexible traverse cross arm, effective as synchronising/safety device as well as torsional lock.
- Pump unit integrated in the cassette.
- Push button control for lifting/lowering with lockable main switch.
- Installation in a waterproof cassette.  
On request: dipped galvanized and/or self-carrying.

- Two on-floor repair platforms, extendable from 1400-2200 mm.

## OPTIONAL

- The optional xy-heads increase the comfort and the lifting area.
- Other accessories on request.

## COLOUR

### Standard paint

galvanized and painted  
RAL 9006

### Special paint:

On request

## MOREOVER

Our expert consultants would appreciate to help you with the planning of a new garage or the modernization of an existing one. We offer to work out a workshop concept including an equipment proposal. Please do not hesitate to contact us.

